

**GLASS PASSIVATED SUPER FAST RECTIFIER**

**VOLTAGE 200 Volts CURRENT 4.0 Amperes**

**FEATURES**

- \* High reliability
- \* Low leakage
- \* Low forward voltage
- \* High current capability
- \* Super fast switching speed
- \* High surge capability
- \* Good for switching mode circuit

**MECHANICAL DATA**

- \* Case: Molded plastic
- \* Epoxy: Device has UL flammability classification 94V-0
- \* Lead: MIL-STD-202E method 208C guaranteed
- \* Mounting position: Any
- \* Weight: 1.18 grams



**DO-201AD**

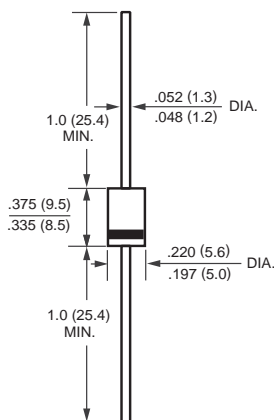

**MAXIMUM RATINGS AND ELECTRICAL CHARACTERISTICS**

Ratings at 25 °C ambient temperature unless otherwise specified.  
 Single phase, half wave, 60 Hz, resistive or inductive load.  
 For capacitive load, derate current by 20%.

**MAXIMUM RATINGS** (At TA = 25°C unless otherwise noted)

RATINGS	SYMBOL	SF44	UNITS
Maximum Recurrent Peak Reverse Voltage	VRRM	200	Volts
Maximum RMS Volts	VRMS	140	Volts
Maximum DC Blocking Voltage	Vdc	200	Volts
Maximum Average Forward Current at TA = 55°C	Io	4.0	Amps
Peak Forward Surge Current IFM (surge):8.3 ms single half sine-wave superimposed on rated load (JEDEC method)	IFSM	125	Amps
Typical Junction Capacitance (Note 2)	Cj	50	pF
Operating and Storage Temperature Range	TJ, TSTG	-55 to + 175	°C

**ELECTRICAL CHARACTERISTICS** (At TA = 25°C unless otherwise noted)

CHARACTERISTICS	SYMBOL	SF44	UNITS
Maximum Forward Voltage at 4.0A DC	VF	0.95	Volts
Maximum DC Reverse Current at Rated DC Blocking Voltage	IR	@ TA = 25°C	5.0
		@ TA = 150°C	50
Maximum Reverse Recovery Time (Note 1)	trr	20	nSec

NOTES : 1. Test Conditions: IF=0.5A, IR=-1.0A, IRR=-0.25A.  
 2. Measured at 1 MHz and applied reverse voltage of 4.0 volts.

# RATING AND CHARACTERISTIC CURVES ( SF44 )

FIG. 1 - TEST CIRCUIT DIAGRAM AND REVERSE RECOVERY TIME CHARACTERISTIC

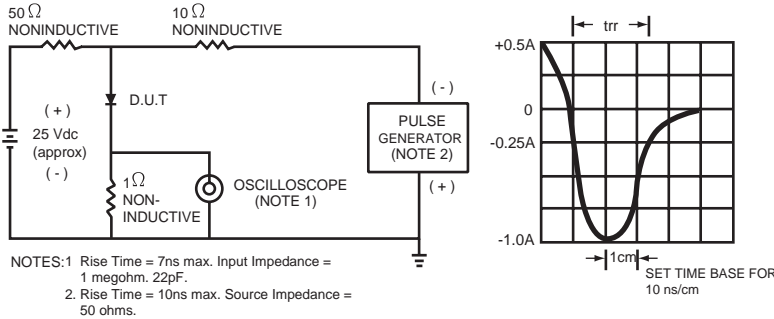

FIG. 3 - TYPICAL REVERSE CHARACTERISTICS

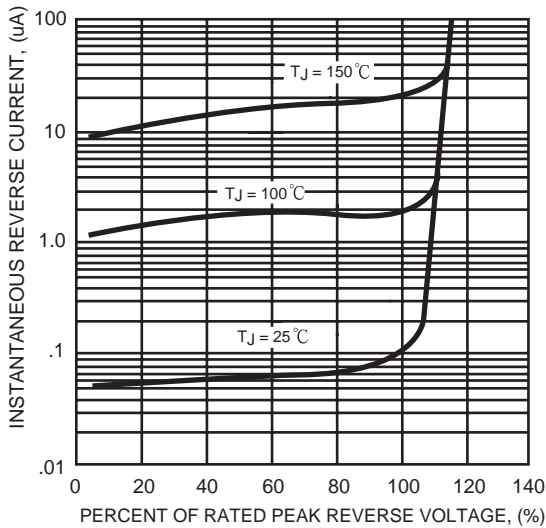

FIG. 5 - MAXIMUM NON-REPETITIVE FORWARD SURGE CURRENT

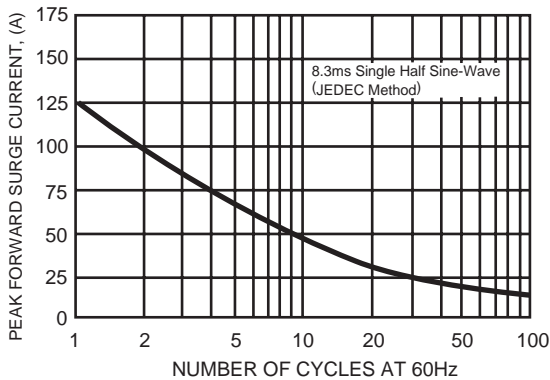

FIG. 2 - TYPICAL FORWARD CURRENT DERATING CURVE

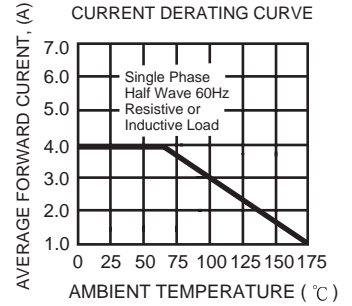

FIG. 4 - TYPICAL INSTANTANEOUS FORWARD CHARACTERISTICS

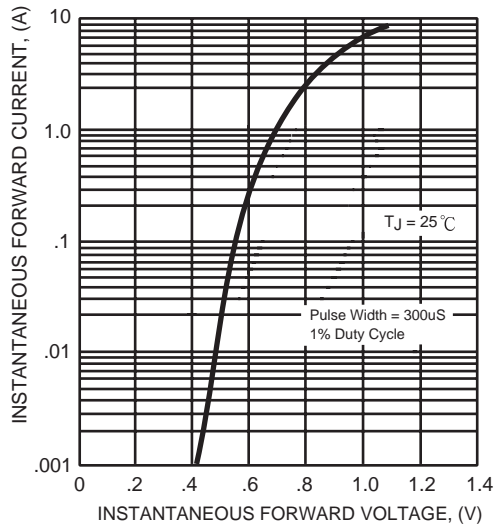

FIG. 6 - TYPICAL JUNCTION CAPACITANCE

