

**GLASS PASSIVATED JUNCTION TRANSIENT VOLTAGE SUPPRESSOR
VOLTAGE-5.0 TO 190 VOLTS
400 WATTS PEAK POWER 1.0 WATT STEADY STATE**

FEATURES

- * Plastic package
- * 400W surge on 10/1000 uS waveform
- * Glass passivated chip junction in SOD-123F Package
- * Excellent clamping capability
- * Low Zener Impedance
- * High temperature soldering guaranteed: 260 °C/10second

MAXIMUM RATINGS AND ELECTRICAL CHARACTERISTICS

Ratings at 25°C ambient temperature unless otherwise specified.
Single phase, half wave, 60 Hz, resistive or inductive load.
For capacitive load, derate current by 20%.

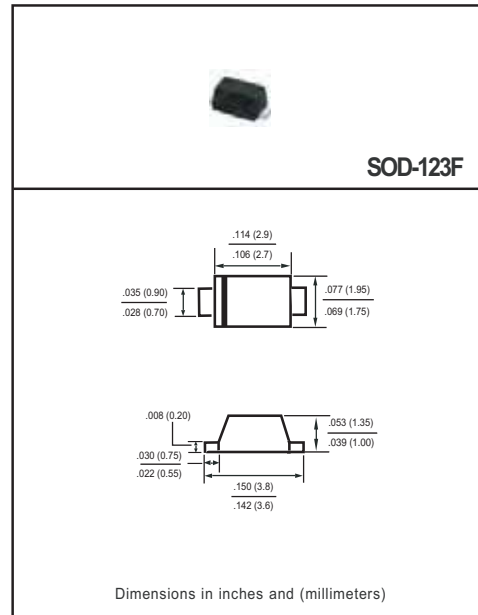

DEVICES FOR BIDIRECTIONAL APPLICATIONS

For Bidirectional use C Suffix (ex. 4SMF5.0CA) Electrical characteristics apply in both directions.

MAXIMUM RATINGS (At TA = 25°C unless otherwise noted)

RATINGS	SYMBOL	VALUE	UNITS
Peak Power Dissipation On 10/1000 uS Waveform	PPK	Minimum 400	Watts
Steady State Power Dissipation at TL = 75°C	PD	1.0	Watts
Peak Forward Surge Current 8.3ms Single Half Sine-Wave Superimposed on Rated Load	IFSM	20	Amps
Typical Current Squared Time	I ² t	1.66	A ² S
Operating and Storage Temperature Range	TJ, TSTG	-65 to +175	°C

Part No.	Reverse Stand-off Voltage	Breakdown Voltage		Test Current	Reverse Leakage		Max Clamp Voltage	Peak Pulse Current
	VRWM	V _{BR} @ I _T		I _T	IR@VRWM		V _C @ I _{PP}	I _{PP}
		Min	Max		UNI	BI		
Unit	V	V	V	mA	µA	µA	V	A
400 W Transient Voltage Suppressors								
4SMF5.0A	5	6.4	7.07	10	800	1600	9.2	40.1
4SMF6.0A	6	6.67	7.37	10	800	1600	10.3	35.9
4SMF6.5A	6.5	7.22	7.98	10	500	1000	11.2	33.1
4SMF7.0A	7	7.78	8.6	10	200	400	12	30.9
4SMF7.5A	7.5	8.33	9.21	1.0	100	200	12.9	28.7
4SMF8.0A	8	8.89	9.83	1.0	50	100	13.6	27.2
4SMF8.5A	8.5	9.44	10.4	1.0	10	20	14.4	25.7
4SMF9.0A	9	10	11.1	1.0	5.0	10	15.4	24.1
4SMF10A	10	11.1	12.3	1.0	5.0	10	17	23.5
4SMF11A	11	12.2	13.5	1.0	5.0	5.0	18.2	22.0
4SMF12A	12	13.3	14.7	1.0	5.0	5.0	19.9	20.1
4SMF13A	13	14.4	15.9	1.0	5.0	5.0	21.5	18.6
4SMF14A	14	15.6	17.2	1.0	5.0	5.0	23.2	17.2
4SMF15A	15	16.7	18.5	1.0	5.0	5.0	24.4	16.4
4SMF16A	16	17.8	19.7	1.0	5.0	5.0	26	15.4
4SMF17A	17	18.9	20.9	1.0	5.0	5.0	27.6	14.5
4SMF18A	18	20	22.1	1.0	5.0	5.0	29.2	13.7
4SMF19A	19	21.1	23.3	1.0	5.0	5.0	30.6	13.0
4SMF20A	20	22.2	24.5	1.0	5.0	5.0	32.4	12.3
4SMF22A	22	24.4	26.9	1.0	5.0	5.0	35.5	11.3
4SMF24A	24	26.7	29.5	1.0	5.0	5.0	38.9	10.3
4SMF26A	26	28.9	31.9	1.0	5.0	5.0	42.1	9.5
4SMF28A	28	31.1	34.4	1.0	5.0	5.0	45.4	8.8
4SMF30A	30	33.3	36.8	1.0	5.0	5.0	48.4	8.3
4SMF33A	33	36.7	40.6	1.0	5.0	5.0	53.3	7.5
4SMF36A	36	40	44.2	1.0	5.0	5.0	58.1	6.9
4SMF40A	40	44.4	49.1	1.0	5.0	5.0	64.5	6.2
4SMF43A	43	47.8	52.8	1.0	5.0	5.0	69.4	5.8
4SMF45A	45	50	55.3	1.0	5.0	5.0	72.7	5.5
4SMF48A	48	53.3	58.9	1.0	5.0	5.0	77.4	5.2
4SMF51A	51	56.7	62.7	1.0	5.0	5.0	82.4	4.9
4SMF54A	54	60	66.3	1.0	5.0	5.0	87.1	4.6
4SMF58A	58	64.4	71.2	1.0	5.0	5.0	93.6	4.3
4SMF60A	60	66.7	73.7	1.0	5.0	5.0	96.8	4.1
4SMF64A	64	71.1	78.6	1.0	5.0	5.0	103	3.9
4SMF70A	70	77.8	86	1.0	5.0	5.0	113	3.5
4SMF75A	75	83.3	92.1	1.0	5.0	5.0	121	3.3
4SMF78A	78	86.7	95.8	1.0	5.0	5.0	126	3.2
4SMF80A	80	88.8	97.6	1.0	5.0	5.0	129	3.1
4SMF85A	85	94.4	104	1.0	5.0	5.0	137	2.9
4SMF90A	90	100	111	1.0	5.0	5.0	146	2.7
4SMF100A	100	111	123	1.0	5.0	5.0	162	2.5
4SMF110A	110	122	135	1.0	5.0	5.0	177	2.3
4SMF120A	120	133	147	1.0	5.0	5.0	193	2.1
4SMF130A	130	144	159	1.0	5.0	5.0	209	1.9
4SMF140A	140	155	171	1.0	5.0	5.0	224	1.8
4SMF150A	150	167	185	1.0	5.0	5.0	243	1.6
4SMF160A	160	178	197	1.0	5.0	5.0	259	1.5
4SMF170A	170	189	209	1.0	5.0	5.0	275	1.4
4SMF180A	180	201	222	1.0	5.0	5.0	292	1.3
4SMF190A	190	211	232	1.0	5.0	5.0	324	1.2

NOTE : 1. V_F = 3.5V AT I_F = 12A ON 1/2 SQUARE OR EQUIVALENT SINE WAVE. PW = 8.3mS, DUTY CYCLE =4 PULSES PER MINUTE MAXIMUM
2. MOUNTED ON 5.0mm² COPPER PADS TO EACH TERMINAL

RATING AND CHARACTERISTICS CURVES (4SMF5.0A THRU 4SMF190CA)

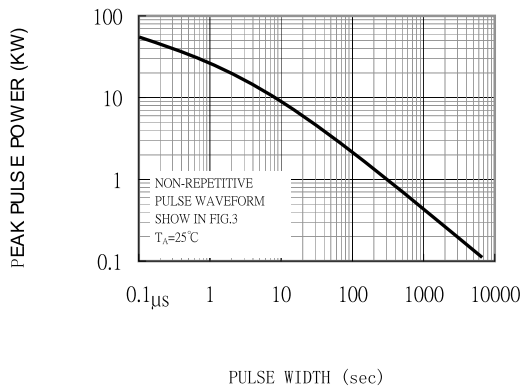

FIG. 1 - PEAK PULSE POWER RATING CURVE

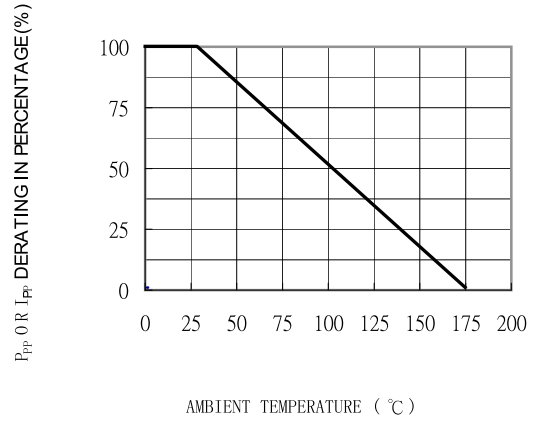

FIG. 2 - PULSE DERATING CURVE

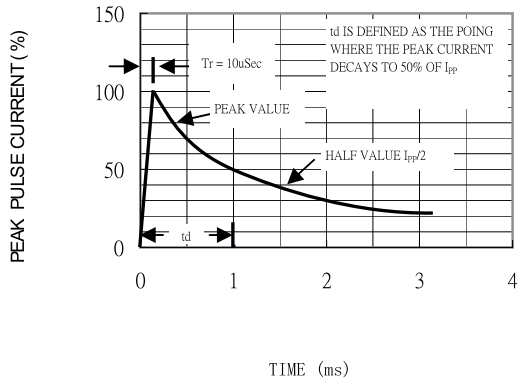

FIG. 3 - PULSE WAVEFORM

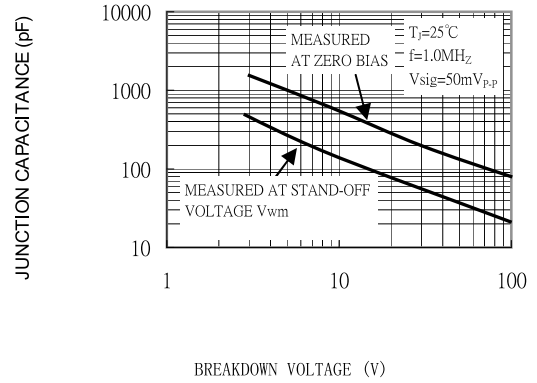

FIG. 4 - TYPICAL JUNCTION CAPACITANCE

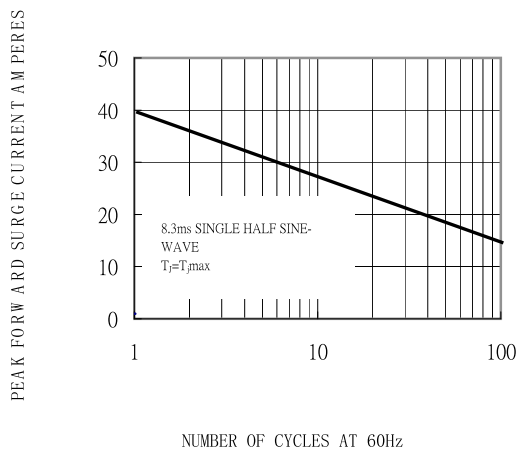
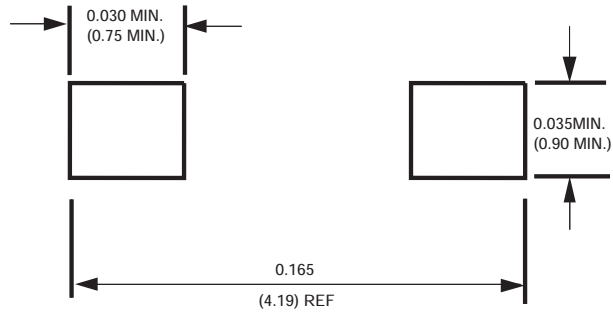

FIG. 5 - MAXIMUM NON-REPETITIVE PEAK FORWARD SURGE CURRENT UNIDIRECTIONAL ONLY

Mounting Pad Layout



Dimensions in inches and (millimeters)

1. Internal Circuit



2. Marking on the body

1) 4SMFXXA

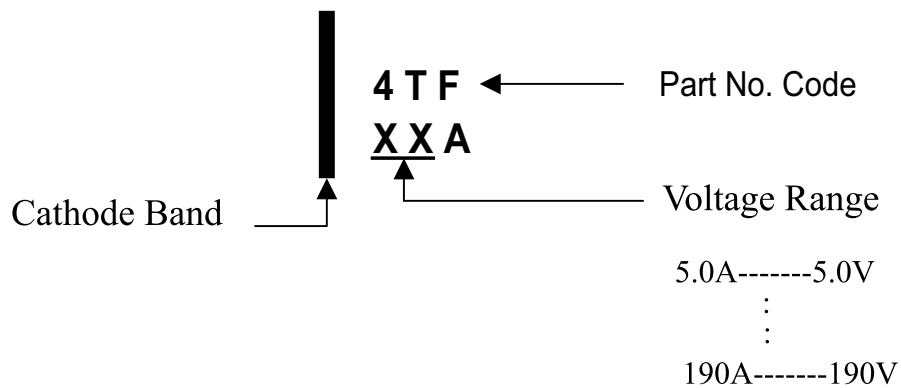

2) 4SMFXXCA

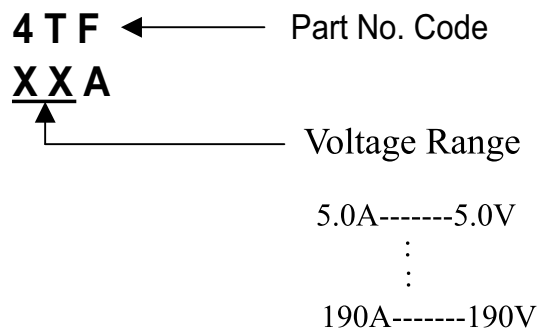

PACKAGING OF DIODE AND BRIDGE RECTIFIERS

REEL PACK

PACKAGE	PACKING CODE	EA PER REEL	EA PER INNER BOX	COMPONENT SPACE (mm)	TAPE SPACE (mm)	REEL DIA (mm)	CARTON SIZE (mm)	EA PER CARTON	GROSS WEIGHT(Kg)
SOD-123F/ SOD-123FL	-W/T	3,000	15,000	---	---	178	390*205*310	120,000	6.964

DISCLAIMER NOTICE

Rectron Inc reserves the right to make changes without notice to any product specification herein, to make corrections, modifications, enhancements or other changes. Rectron Inc or anyone on its behalf assumes no responsibility or liability for any errors or inaccuracies. Data sheet specifications and its information contained are intended to provide a product description only. "Typical" parameters which may be included on RECTRON data sheets and/ or specifications can and do vary in different applications and actual performance may vary over time. Rectron Inc does not assume any liability arising out of the application or use of any product or circuit.

Rectron products are not designed, intended or authorized for use in medical, life-saving implant or other applications intended for life-sustaining or other related applications where a failure or malfunction of component or circuitry may directly or indirectly cause injury or threaten a life without expressed written approval of Rectron Inc. Customers using or selling Rectron components for use in such applications do so at their own risk and shall agree to fully indemnify Rectron Inc and its subsidiaries harmless against all claims, damages and expenditures.